

ROOF ACCESSORIES - THERMALBLOCK SERIES - Thermally Broken Roof Hatch - RHTB

The ThermalBlock thermally broken roof hatch provides superior energy efficiency with R-20 insulation in both curb and cover which reduces condensation and building energy costs.

LADDER ACCESS

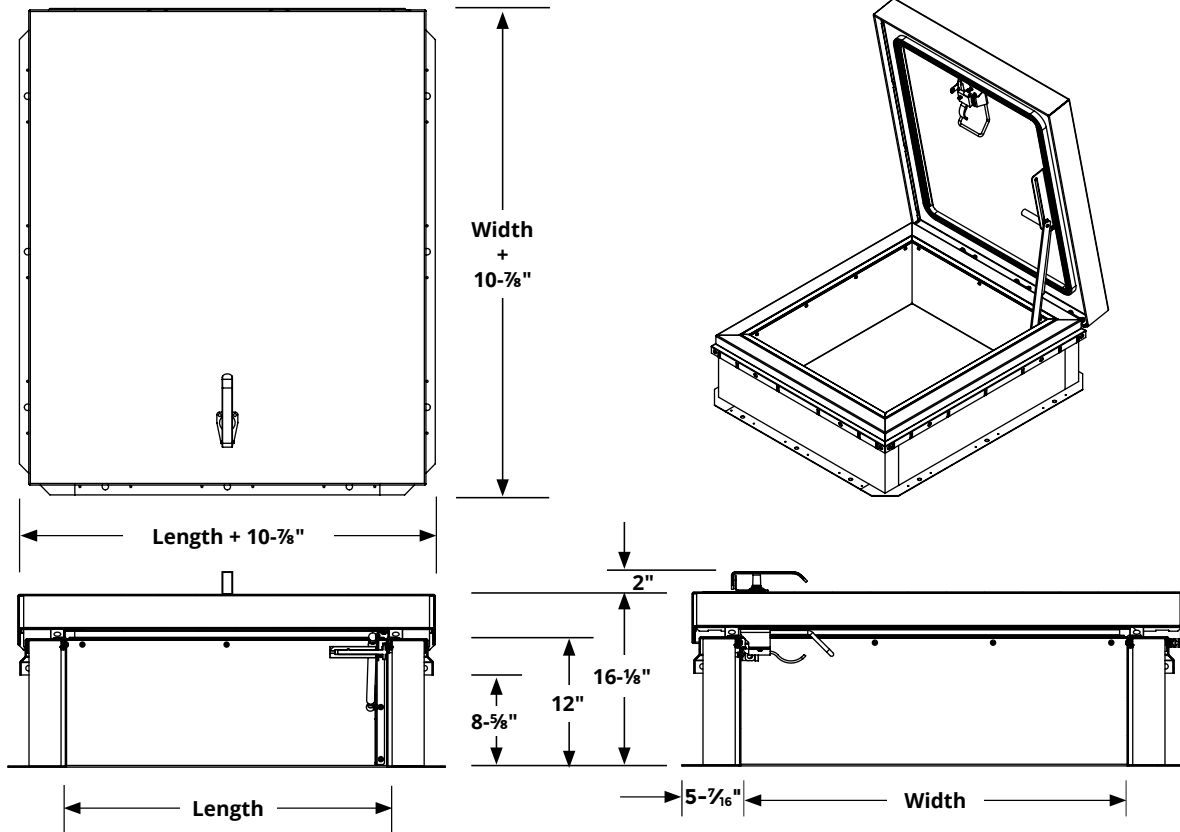

SPECIFICATIONS:

Material: 11 gauge aluminum

Standard Finish: Mill

Curb: Thermally broken single wall curb and counterflashing with tabs.

Cover: Thermally broken cover stiffened to support a live load of 40psf.

Gasket: Continuous, weatherproof EPDM sponge rubber adhesive-backed seal

Insulation: 3" polyisocyanurate in curb and cover with thermal resistance R-20

Spring: Gas spring with integrated damper for smooth, controlled lift assistance.

Latch: Zinc-plated steel slam latch with inside and outside handles and padlock hasps; 20psf wind uplift

Hold Open Arm: Zinc-plated steel automatic hold open arm locks cover in open position.

Hinge: Heavy duty zinc-plated steel pintle hinge.

Sizing: Minimum: 26" x 24", Maximum: 48" x 48" or 30" x 96"

Clear opening: (Width - 8") x (Length - 1/2")

OPTIONS:

Optional Construction: Double wall curb

NOTE:

For pitched roofs up to 7:12, mount hinge side parallel to slope. Door opens 80°.

STANDARD RHTBA

QTY	MODEL	W X L	ACCESS	WEIGHT
	RHTBA-1	36"x 30"	Ladder	107 lbs
	RHTBA-2	30"x 54"	Stair	128 lbs
	RHTBA-3	30"x 96"	Stair	172 lbs
	RHTBA-4	36"x 36"	Ladder	145 lbs
	RHTBA-5	48"x 48"	Ladder	235 lbs

ACTIVAR
CONSTRUCTION PRODUCTS GROUP INC.



800-554-6077
sales@activarcpg.com
www.activarcpg.com

9702 Newton Ave S. Bloomington, MN 55431 | Many Locations Nationwide

Distributor:

Project:

Contractor:

Approved By:

Date:

Architect:

Scale: N/A

Pages: 1 of 1

Item #:

ROOF ACCESSORIES - THERMALBLOCK SERIES - Thermally Broken Roof Hatch - RHTB

MADE-TO-ORDER RHTB

QTY	MODEL	MATERIAL	SIZES	FINISH	CURB OPTIONS												
<input type="text"/>	RHTB	A (Aluminum)	<table border="1"> <tr><td>1</td><td>(36" x 30")</td></tr> <tr><td>2</td><td>(30" x 54")</td></tr> <tr><td>3</td><td>(30" x 96")</td></tr> <tr><td>4</td><td>(36" x 36")</td></tr> <tr><td>5</td><td>(48" x 48")</td></tr> </table>	1	(36" x 30")	2	(30" x 54")	3	(30" x 96")	4	(36" x 36")	5	(48" x 48")	(Mill)	<table border="1"> <tr><td>(Single Wall Curb)</td></tr> <tr><td>CD (Double Wall Curb)</td></tr> </table>	(Single Wall Curb)	CD (Double Wall Curb)
1	(36" x 30")																
2	(30" x 54")																
3	(30" x 96")																
4	(36" x 36")																
5	(48" x 48")																
(Single Wall Curb)																	
CD (Double Wall Curb)																	
			<table border="1"> <tr><th>WIDTH</th><th>LENGTH</th></tr> <tr><td><input type="text"/></td><td><input type="text"/></td></tr> </table>	WIDTH	LENGTH	<input type="text"/>	<input type="text"/>										
WIDTH	LENGTH																
<input type="text"/>	<input type="text"/>																

STAIR ACCESS

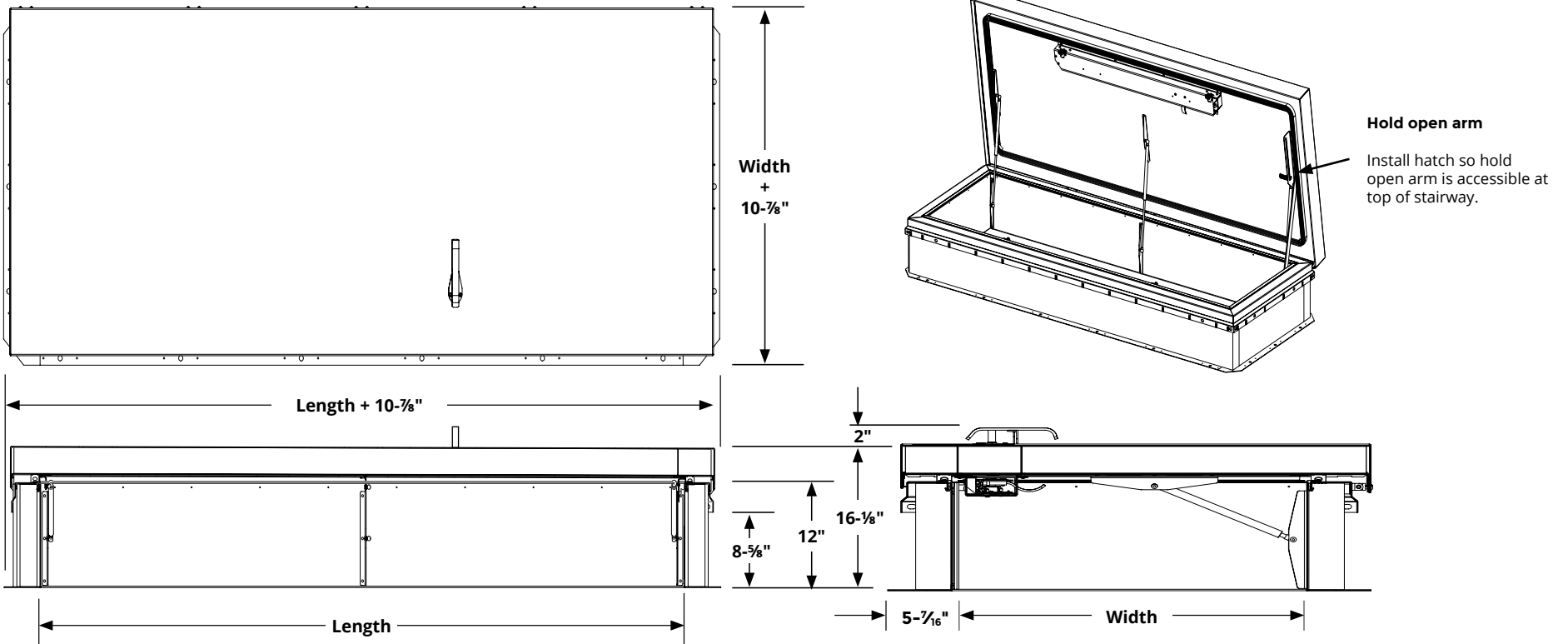

800-554-6077
 sales@activarcpg.com
 www.activarcpg.com

9702 Newton Ave S. Bloomington, MN 55431 | Many Locations Nationwide

Distributor:	Project:
Contractor:	Approved By:
Date:	Architect:
Scale: N/A	Pages: 1 of 1
Item #:	