

CORNER GUARDS—ENDWALL CGS SERIES

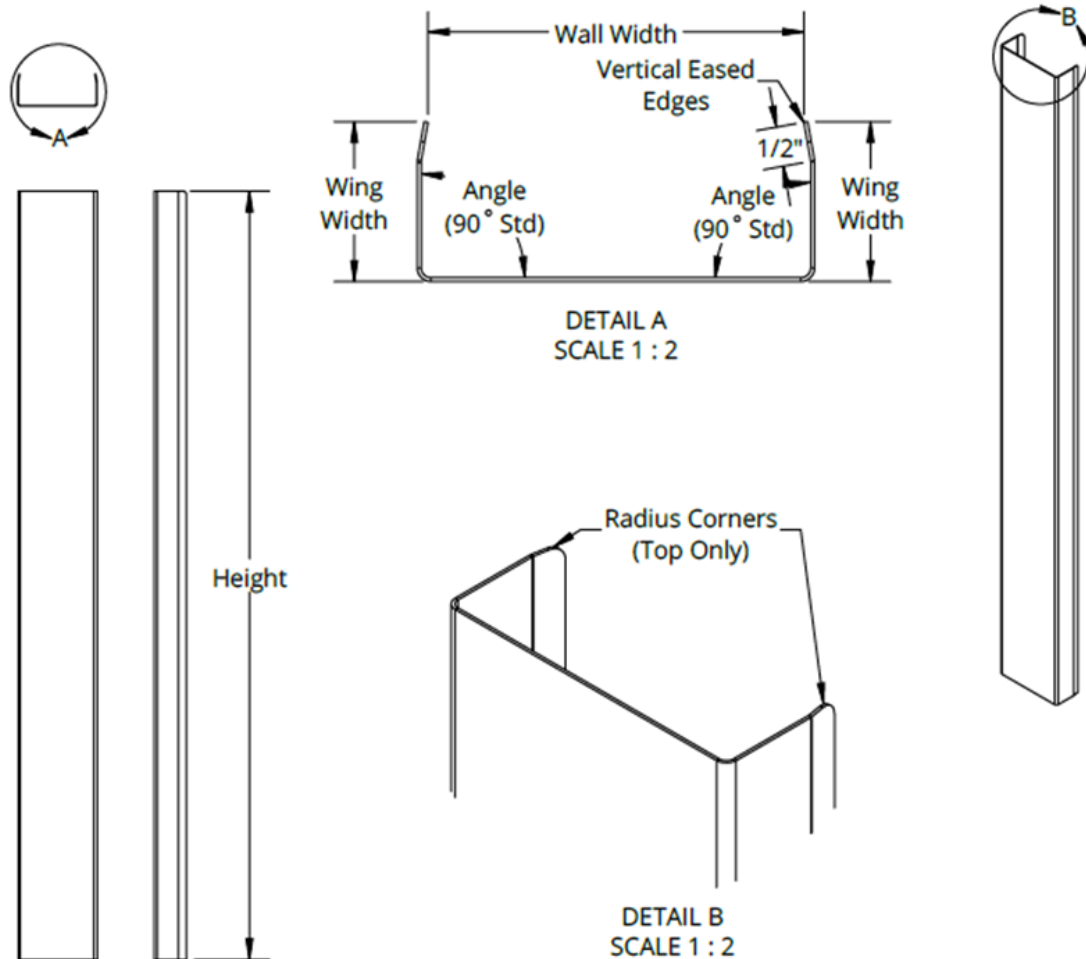

SPECIFICATIONS:

Material: 18 gauge stainless steel #4 finish US32D (BHMA 630), grain direction is parallel to the height

Wing width: Common sizes—1-1/2", 2", 2-1/2", 3", 3-1/2" wing on two sides with vertical eased edges.

Minimum 1", Maximum 36".

Height: Minimum - 12"; Maximum - 108"

Angle: 90 degree with 1/8" radius

Installation: Top corners are radius, bottom corners are square

Mounting Options:

- Standard corner guards mount using adhesive ordered separately. Off white water-based construction adhesive PL375 (CG-KIT-ADH-PL). 10 oz tube for approximately 30 linear feet.
- Countersunk holes with 1-1/4" #8 SS self-drilling screws (H)
- Double sided tape applied (T)

OPTIONS:

Material: .050 anodized Aluminum
16gauge stainless steel
#7 18 gauge stainless steel finish

Features: 3/4" Bullnose radius corner

COMPLIES:

Stainless steel - ASTM A240-7

NOTES:

Screws only available for wing sizes over 1-1/2" and up, and wall width of 1-1/2" or greater.

Complete the made-to-order table on page 2, to order this product.

 JL INDUSTRIES 9702 Newton Av S. Bloomington, MN 55431 Many Locations Nationwide @ 2023 Activar Construction Products Group, Inc.	800-554-6077 sales@activarcpg.com www.activarcpg.com	Distributor:	Project:
		Contractor:	Approved By:
	Date:	Quantity:	Architect:
	Scale: N/A	Pages: 1 of 2	Item #

THE INFORMATION CONTAINED IN THIS DOCUMENT IS THE SOLE PROPERTY OF ACTIVAR CONSTRUCTION PRODUCTS GROUP, INC. ANY REPRODUCTION IN PART OF AS A WHOLE WITHOUT THE WRITTEN PERMISSION OF ACTIVAR CONSTRUCTION PRODUCTS GROUP, INC. IS PROHIBITED.

Countersunk Hole Locations Shown Below

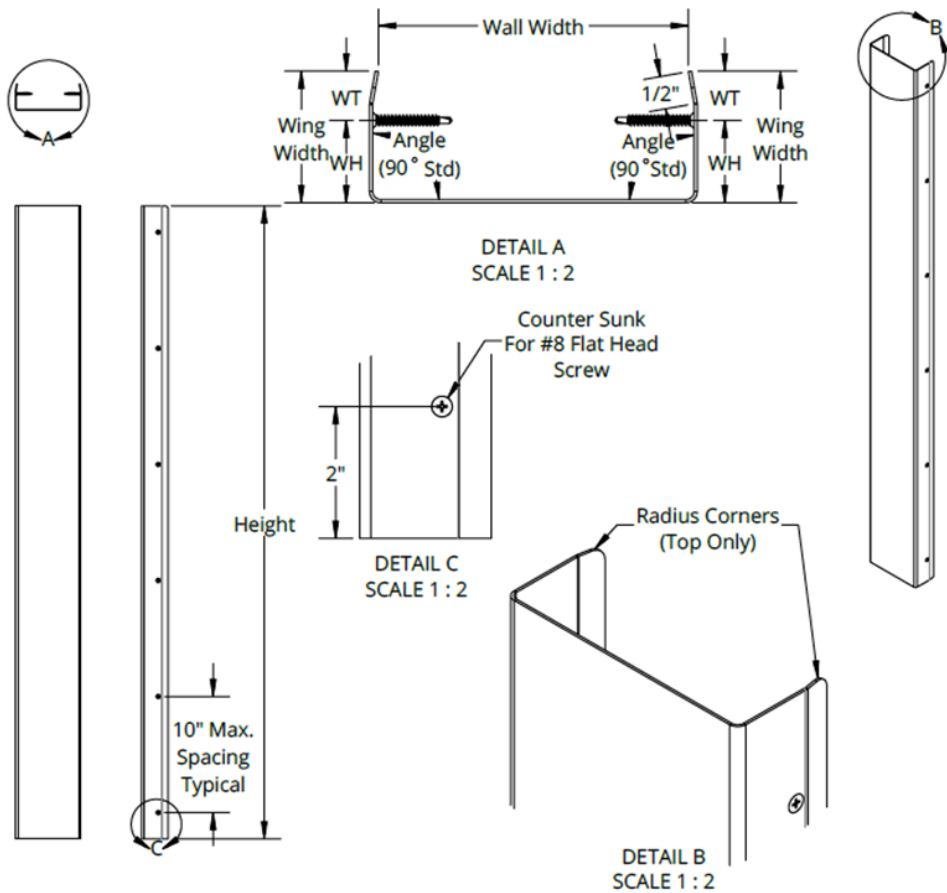

Hole Position on Wing		
Wing Size	WT	WH
1 1/2" to 3"	3/4"	Varies
Over 3"	Varies	2"

Adhesive Ordered Separately—Check Here	
CG-KIT-ADH-PL	
PL375 Off White Water-based Construction Adhesive. 10 oz tube for approximately 30 linear feet. (# of tubes will be calculated based on your order)	

MADE-TO-ORDER CORNER GUARD—EXAMPLE: CGSS-7.5-2.5E-96H

MODEL	MATERIAL	ENDWALL WIDTH	WING WIDTH	EDGE	HEIGHT	MOUNTING	OPTIONS
CG	SS Stainless Steel #4 - 18 gauge (Std)	5.5 5-1/2"	1.5 1.5"	E Eased Edge (Standard)	48 48"	None (Adhesive ordered separately)	BN 3/4" Radius Bullnose
	SH Stainless Steel #4 - 16 gauge	8 8"	2 2"		96 96"		
	AL Aluminum - .050	Other	2.5 2.5"	Other Size	H Countersunk Holes	F7 #7 Polished Finish—18 gauge	
			3 3"				T Tape Applied
			Other				

It is the responsibility of the customer to communicate specifications and product performance requirements that are needed for their application. This document is intended to convey potential product configurations and offerings. It is not to be used to imply or represent a specification or rating, of finished products shipped. Detailed, specific submittals can be created upon request. It is the responsibility of the customer to specify product accordingly to comply with local laws, codes, and ordinances.