

# DURA-HATCH™ EQUIPMENT SERIES ROOF HATCH—REH & REHV

## INSTALLATION AND MAINTENANCE GUIDE | 14I-412

### GENERAL:

Equipment hatches are designed for equipment installation and maintenance from the roof. The following guide suggests recommendations; please install according to local building codes.

When mounting roof hatch on pitched roofs up to 2:12, mount hinge side parallel to slope.

Caution: Roof hatch cover is spring loaded. Make sure hatch is in horizontal position prior to opening cover.

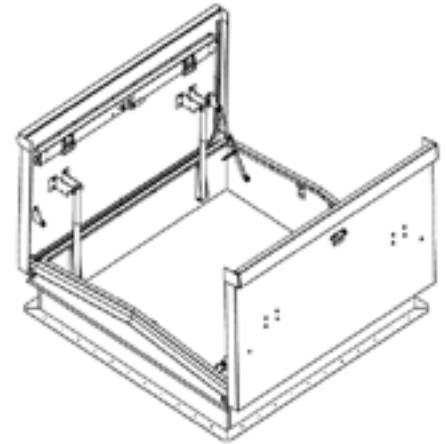

### INSTALLATION:

1. Prepare opening through roof deck of width and length as specified by details on submittal drawing. The roof opening size is equal to the roof hatch size, which is measured inside curb to inside curb. • A roof hatch that measures 60" width (hinge to latch) x 96" length (hinge side), will have a roof rough opening of 60"x96".
2. Opening must be positioned so as to not impair structural integrity of roof. Supporting structure must withstand lateral and thermal stresses as well as load pressures. Opening must be positioned so as to not impair structural integrity of roof. Supporting structure must withstand lateral and thermal stresses as well as load pressures.
3. Check that the frame rests flat on plane and is not twisted or uneven. Shim if required, to ensure proper operation.
4. Secure the curb flange to steel angle or other framed opening in the roof using fasteners (by others) through the 0.19" mounting holes provided in the base flange. Recommended fasteners are #10 screws, when securing to a wood frame. For larger bolts, drill larger mounting holes through the metal flange.
5. Complete the roofing installation in accordance with local building codes and accepted roofing industry practices.
6. Remove steel safety bands from door sides.
7. CAUTION: Doors are spring loaded and may pop open, if latches moved during shipping.

### OPERATION:

**CAUTION: LID IS SPRING LOADED. Please open lid with caution**

1. Open from the outside; roof hatch is opened by turning the exterior handle on the one leaf and pulling up until the hold-open arm locks the door in the upright position. Now lift the second leaf, pulling up until the hol-open arm locks the door in the upright position.
2. Close from the outside; Disengage the hold-open arm on the second leaf by pulling the red vinyl grip forward and fully close. Now, disengage the hold-open arm on the first leaf and lower.
8. Ensure the hatch covers are fully latched and secured.



**DUR-RED PRODUCTS**

9702 Newton Ave S. Bloomington, MN 55431 | Many Locations Across North America

800-554-6077

sales@activarcpg.com

www.activarcpg.com

**INSTALLATION AND  
MAINTENANCE GUIDE 14I-412**

REV C | 2/15/2024

# DURA-HATCH™ EQUIPMENT SERIES ROOF HATCH—REH & REHV

## INSTALLATION AND MAINTENANCE GUIDE | 14I-412

### MAINTENANCE:

1. Manually operate once a year to check functionality of moving parts such as latches, hinges and turn handles.
2. Test outside and inside manual operation of latches. Rotate exterior handle from exterior to release slam latch and open door. Adjust (if required) latch keepers to insure full secure latching in closed position.
3. Periodically clean latches and strikes of old grease and dirt and reapply new grease as needed.
4. Painted surfaces can be cleaned with a mild soap and water solution.
5. When applicable, clean domes with a mild soap and water solution - do not use abrasive cleaners or cleaning cloths. Rinse well and remove remaining excess water. To protect the surface, apply a thin even coat of an automobile paste wax (not a cleaner-wax combination). Buff lightly with a soft, clean cloth. Fine scratches may be removed or minimized by using an automobile cleaner/polish. Test on small section to make sure results are what you want.

### REPAINTING AND RECOATING SUGGESTIONS:

**Dura-Hatches come standard with a powder coat finish.**

#### ***Powder Coat Paint Recoating Suggestions:***

1. Abrade the entire paint surface with an abrasive pad or sandpaper to a dull sheen to ensure the topcoat sticks.
2. It is recommended that all parts be cleaned well, before any paint is applied in the field. After abrading the surface, the parts should be wiped with an alcohol-based product which will clean and help reopen the surface for the best adhesion of the topcoat. Be sure to read the product directions prior to use.
3. Use a high-quality paint that is suitable for metal. Activar Construction Products Group, Inc. cannot accept liability for the performance of specific brands of paint.

#### ***Prime Coat Repainting Suggestions:***

1. Clean or scuff primed surface to remove any grease or contamination present on surface.
2. Solvent wipe with acetone or similar solvent to improve intercoat adhesion.
3. If solvent wiping is impractical, lightly scuff sand and remove all dusts that may inhibit adhesion.
4. Topcoat with high quality 100% acrylic latex or oil-based coatings. Primed surface will also accept coatings with strong solvents such as 2K polyurethanes when cure. Activar Construction Products Group, Inc. cannot accept liability for performance of specific brands of paint.