

Architectural Series, Fire Protection Cabinet, Ambassador - C1013S21
 FE CABINET, AMBASSADOR, SURF MT, SLD, ALL CRS, ALL WHT, 10 SERIES

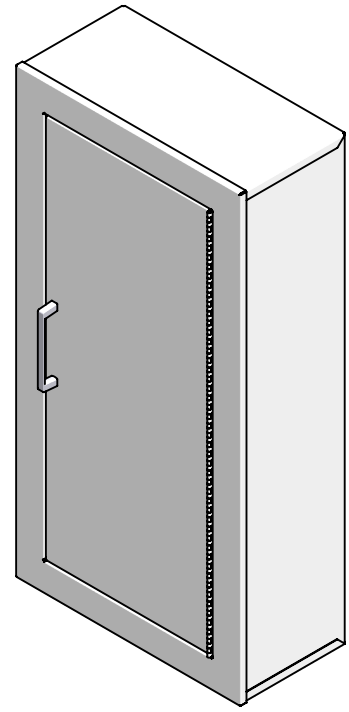
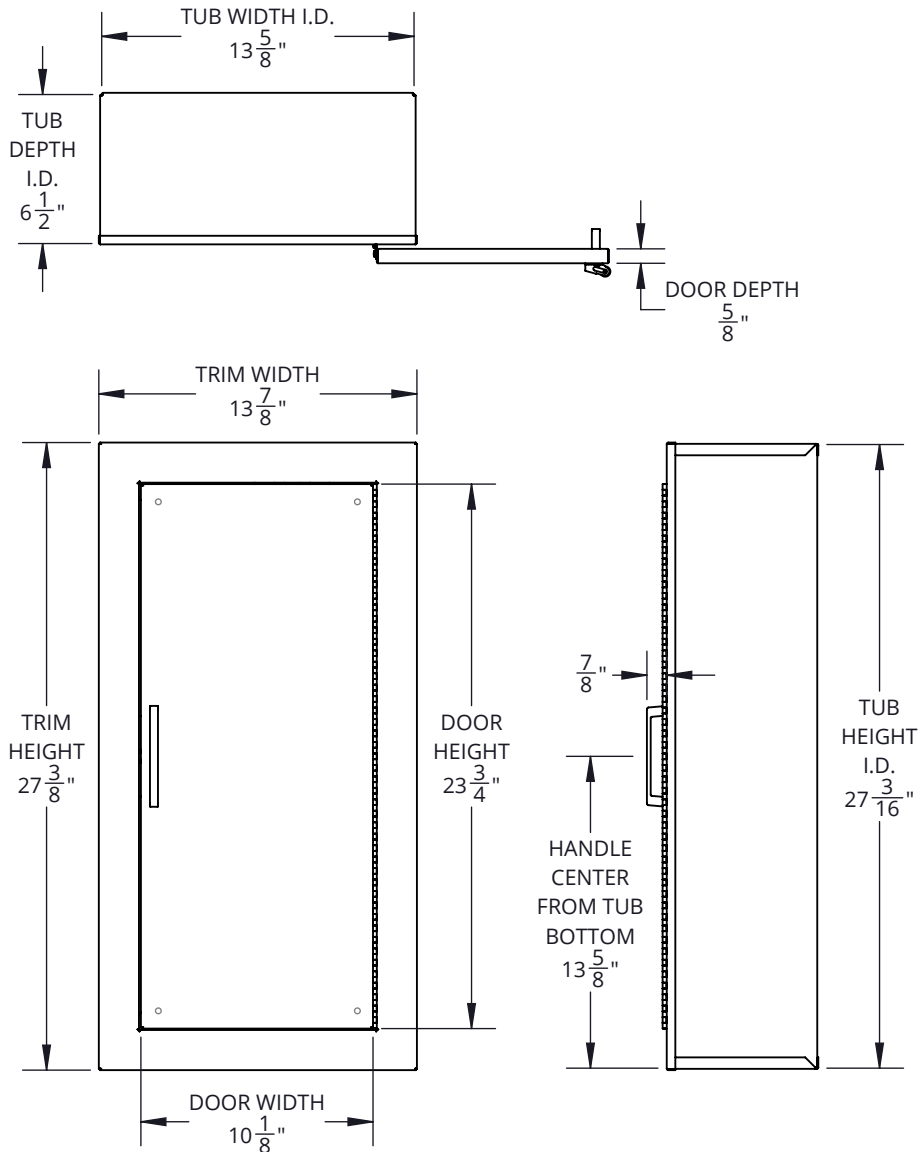

SPECIFICATIONS:

- Tub Material:** 22 gauge CRS
- Trim Material & Style:** 20 gauge CRS, surface mount square edge
- Door Material & Style:** 20 gauge CRS, solid
- Glazing:** None
- Finish:** Powder coat white door, trim, and tub
- Hinge:** Continuous hinge opens door 180 degrees
- Hardware:** Zinc plated pull handle, roller catch, screws
- Mounting Pattern:** 4 1/4" holes, 8-11/16" x 22-3/16"
- Fire Rating:** Not rated
- ADA Compliant:** Cabinet does not meet 4" maximum protrusion.
- Compatible Extinguishers:** Cosmic 2.5lb. - 6lb., Galaxy 2.5 - 5lb, Mercury 2.5lb. - 5lb.

MODEL # BREAKDOWN:

- C — Product Line:** Fire protection, cabinet
- 10 — Tub Size:** 13-11/16" x 27-3/16" x 6-1/2"
- 1 — Trim and Door Material:** CRS, powder coat finish
- 3 — Trim Style:** Surface mount, square edge
- S — Door Style:** Solid (no glazing), roller catch
- 21 — Door Type:** Pull handle
 - **Color:** All white

REPLACEMENT PARTS:

- Tub:** TUB-1013C
- Door:** D-1015
- Hardware Pack:** HPFPUS

MODEL #: C1013S21



800-554-6077
 sales@activarcpg.com
 www.activarcpg.com

9702 Newton Ave S. Bloomington, MN 55431 | Many Locations Nationwide

Distributor:		Project:
Contractor:		Approved By:
Date:	Quantity:	Architect:
Scale: 1:8.375	Pages: 1 OF 1	Drawing #: C1013S21-SUBMITTAL