

FIRE EXTINGUISHER BRACKET - C MODEL EXTINGUISHERS - MB811C

JL Industries optional mounting brackets are a strong and durable choice for mounting your portable fire extinguishers on walls or vehicles.

SPECIFICATIONS:

Material: Steel

Finish: Black powder paint. Meets ASTM B-117.

Test Standards: UL240

Note: Other reference #700229/811

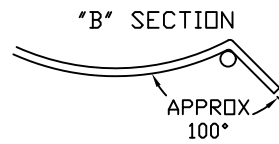
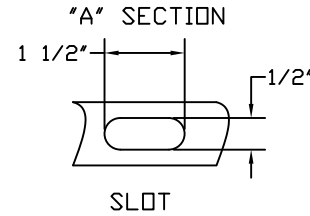
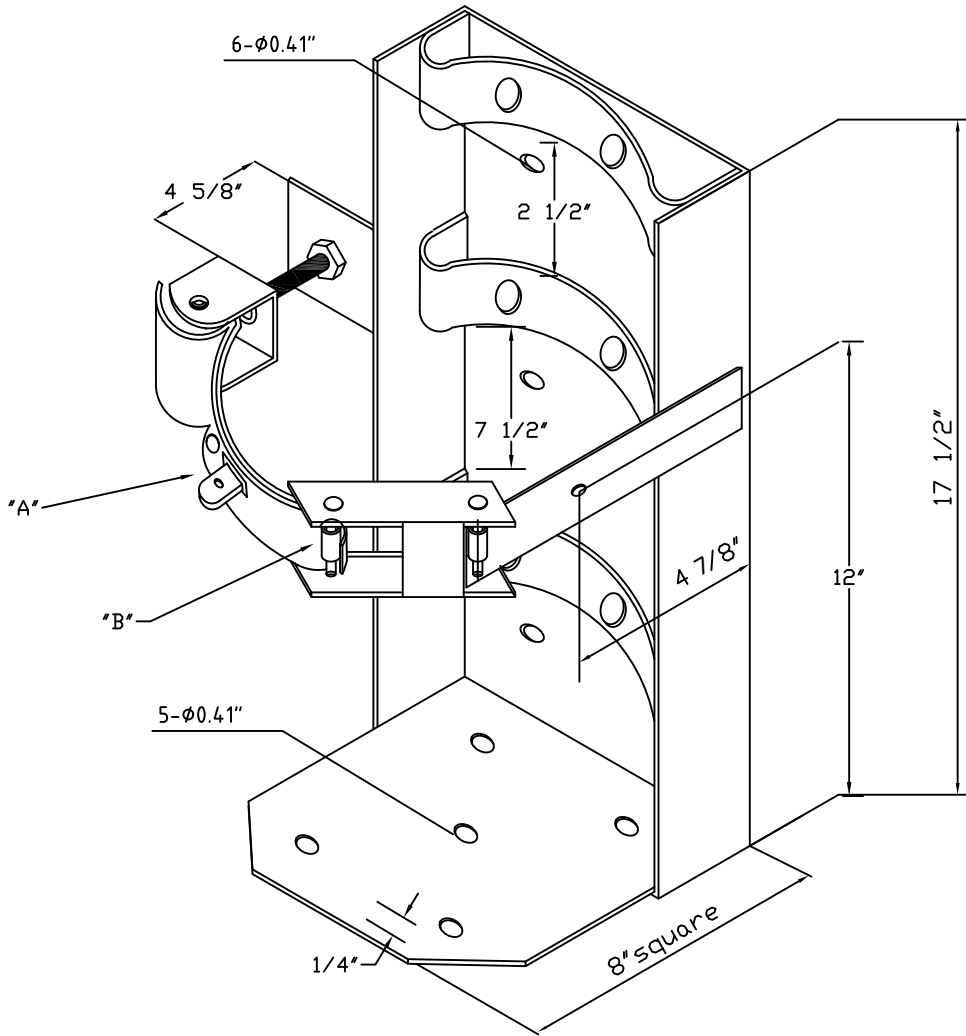

Top View
Latch Mechanism

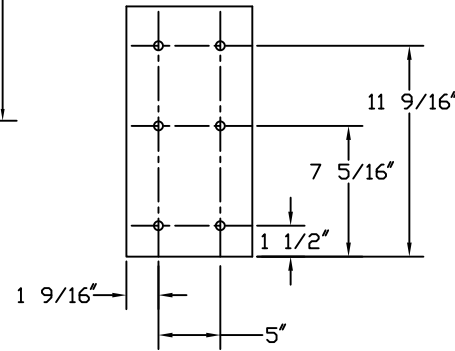

QTY	MODEL	FITS FIRE EXTINGUISHER
	MB811C	FE20C, FE20CBV, FG20C, FS20C, FPK20C, FPK20CBV, FPK30CBV

Back of Bracket

It is the responsibility of the customer to communicate specifications and product performance requirements that are needed for their application. This document is intended to convey potential product configurations and offerings. It is not to be used to imply or represent a specification or rating, of finished products shipped. Detailed, specific submittals can be created upon request. It is the responsibility of the customer to specify product accordingly to comply with local laws, codes, and ordinances.



JL INDUSTRIES

9702 Newton Avenue S, Bloomington, MN 55431

800-554-6077

sales@activarcpg.com

www.activarcpg.com

Distributor:

Contractor:

Date:

Scale: N/A

Project:

Approved By:

Architect:

Item#:

Page 1 of 1