

GLAZING - INSU - Insulated Safety Glazing

Enhance door STC value with an insulated glass unit. Each includes double panes of glass in a complete sealed, insulated glass unit.

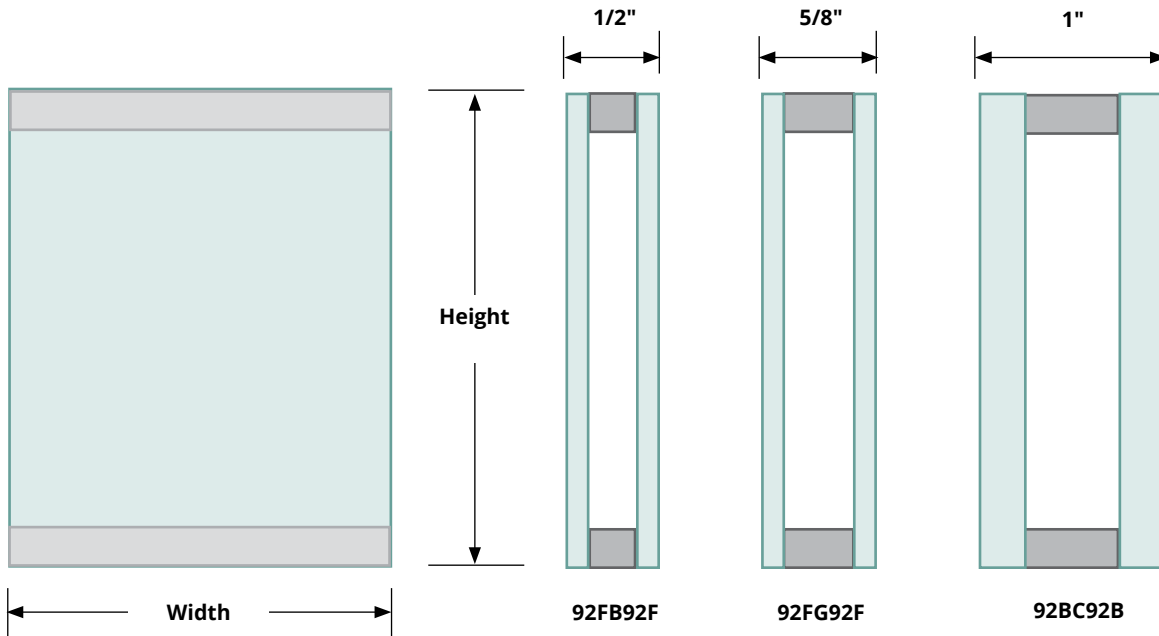

SPECIFICATIONS:

Material: Two panes of clear tempered glass in a sealed insulated glass unit with an air space.

Size:

Minimum: 2" x 2"

Maximum: 96" x 130"

RATINGS:

Impact Safety Rating: CPSC 16CFR 1201 (CAT I & II)

Compatible Frames: Slimline VSIG, EZLine VLFEZIG, ThruBoltLine VLFIG

Warranty: Five year limited

OPTIONS & ACCESSORIES:

Standard Tape: 1/16" x 3/8" wide 200ft, adhesive back, black closed cell polyvinyl chloride foam glazing tape applied to glazing or ordered separately.

TAPE, WHEN ORDERED SEPARATELY	
GTAPE 200B	200' Roll Tape

NOTE:

Order size is actual glass size.
Tempered glass cannot be cut after manufacturing.
Please consult your AHJ to make sure your glazing complies with local ordinances before ordering.



MADE-TO-ORDER INSULATED GLASS - EXAMPLE: INSU 2323-92FG92F

QTY	MODEL	WIDTH	HEIGHT	-	CODE/THICKNESS	DESCRIPTION	(TAPE APPLIED)
	INSU				92FB92F 1/2" (1/8" Temp, 1/4" Spacer, 1/8" Temp)		None
					92FG92F 5/8" (1/8" Temp, 3/8" Spacer, 1/8" Temp)		T (1/16" Standard Tape)
					92BC92B 1" (1/4" Temp, 1/2" Spacer, 1/4" Temp)		
					98BG98B 1" (5/16" LAMI, 3/8" SPACER, 5/16" LAMI)		
					94BC92B 1" (1/4" TEMPLE X 1/2" SPACER, 1/4" TEMP)		
					72BC72B 1" (1/4" PYRO x 1/2" SPACER x 1/4" PYRO)*		

* Pyro insulated with Pyro only

It is the responsibility of the customer to communicate specifications and product performance requirements that are needed for their application. This document is intended to convey potential product configurations and offerings. It is not to be used to imply or represent a specification or rating, of finished products shipped. Detailed, specific submittals can be created upon request. It is the responsibility of the customer to specify product accordingly to comply with local laws, codes, and ordinances.

 <p>AIR LOUVERS</p> <p>9702 Newton Ave S. Bloomington, MN 55431 Many Locations Nationwide</p>	<p>800-554-6077</p> <p>sales@activarcpg.com</p> <p>www.activarcpg.com</p>	<p>Distributor:</p>	<p>Project:</p>
		<p>Contractor:</p>	<p>Approved By:</p>
		<p>Date:</p>	<p>Architect:</p>
		<p>Scale: N/A</p>	<p>Pages: 1 of 1</p>