

## ROOF ACCESSORIES - FARHRENHEIT™ SERIES SMOKE VENT - RVF

Our UL 793 listed double door smoke vents automatically open during a fire with a heat responsive device, releasing harmful smoke and fumes. Smoke vents are required as referenced in International Building Code section 410 for stages, platforms and technical production areas and section 910 for smoke and heat removal in storage and warehouse occupancies.

### SPECIFICATIONS:

**Material:**

**Curb:** 14 gauge galvalume steel

**Cover:** 11 gauge aluminum with 18 gauge aluminum cover liner

**Finish:** Silver textured powder coat paint

**Gasket:** Bulb neoprene door seal

**Insulation:** 1" polyisocyanurate (R-6) on curb and in cover

**Hinge:** Heavy-duty aluminum hinge with bolt pin

**Hold-Open Arm:** Clear zinc-plated steel hold-open arm

**Latch:** Rotary latch mechanism designed to hold covers closed against 90psf wind uplift. Opens manually with internal and external manual pull handles and automatically with fusible link

**Fusible Link:** 165° UL 33 listed fusible link

**Spring:** Gas springs with dampers automatically open against 10PSF snow load

**Size:** 48" x 48"

**ROOF OPENING = ORDER SIZE**

**CERTIFICATIONS:**

UL 793 listed and labeled

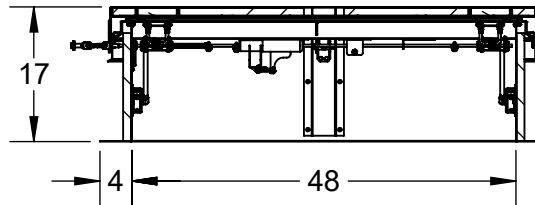
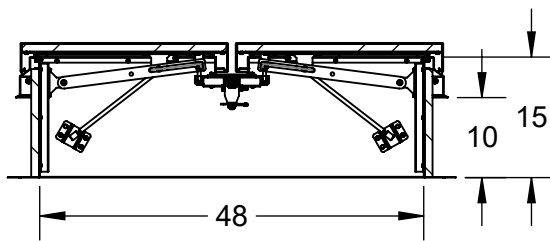
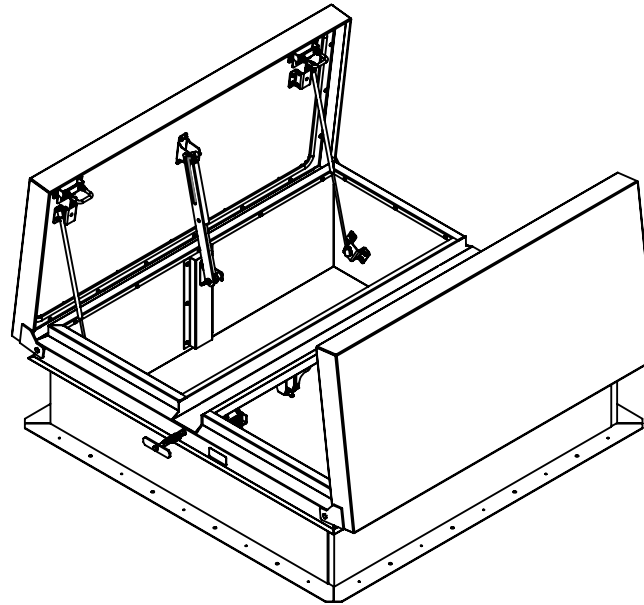
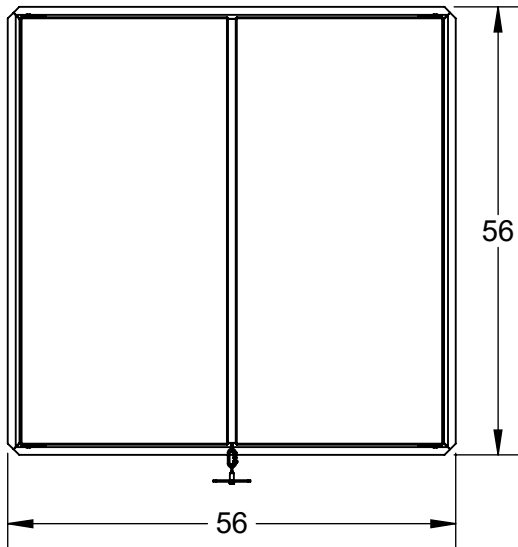

**MODEL #:** RVFGA-4848ST



**DUR-RED PRODUCTS**

9702 Newton Avenue S, Bloomington, MN 55431

800-554-6077

sales@activarcpg.com

www.activarcpg.com

Distributor:		Project:	
Contractor:		Approved By:	
Date:		Architect:	
Scale: 1:24	Pages: 1 OF 1	Drawing #:	RVFGA-4848ST-SUBMITTAL