

GENERAL:

The following guide provides instructions to safely remove and replace JL Industries roof hatch spring cylinders. It is applicable for retrofit spring kits including; RHD-KIT-RETROSPR-G1. This kit is designed to provide lift assistance to all prior generation steel roof hatches sized 36"x30", including model numbers RHGI-1 and RHG-1. Other sized roof hatches may require different springs, based on the weight of the cover. Please contact customer service for further support.

Tools needed: (1) 7/16" wrench, (2) 1/2" wrenches, drill, T30 torx head bit, compression tool, drill bit (provided), spring compression clamp tool.

Timing: We estimate that two people can replace and install two cylinders in approximately 30 minutes.

Caution: Roof hatch spring cylinders are under pressure. Please use the provided spring compression tools to remove and install spring cylinders. We recommend that installers use fall prevention safety equipment while performing this work.

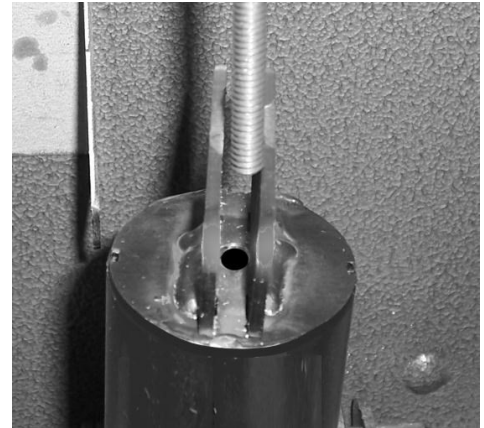

INSTALLATION:

Replace Old Cylinder and Spring Assembly

1. Open roof hatch, engage automatic hold-open arm to hold the lid open while working.
2. The cylinder must be slightly compressed to remove it.
3. To compress, remove rectangular block from the end of the compression tool (shown below) and move washer to the end of the rod with the nut.
4. Insert free end of the rod into the top of the cylinder (shown above), guiding the rod through the center of the spring until it protrudes from the bottom of the bottom cylinder and foot.
5. Screw rectangular block onto the end protruding from the bottom cylinder, by hand until it is snug against the bottom of the bracket (shown to the right).
6. Make sure that the holes in the cylinder top are facing the lid. Using the 7/16" wrench, tighten the threaded nut to compress the shock assembly.
7. Remove bolt "A" that attaches cylinder top to the bracket on lid.

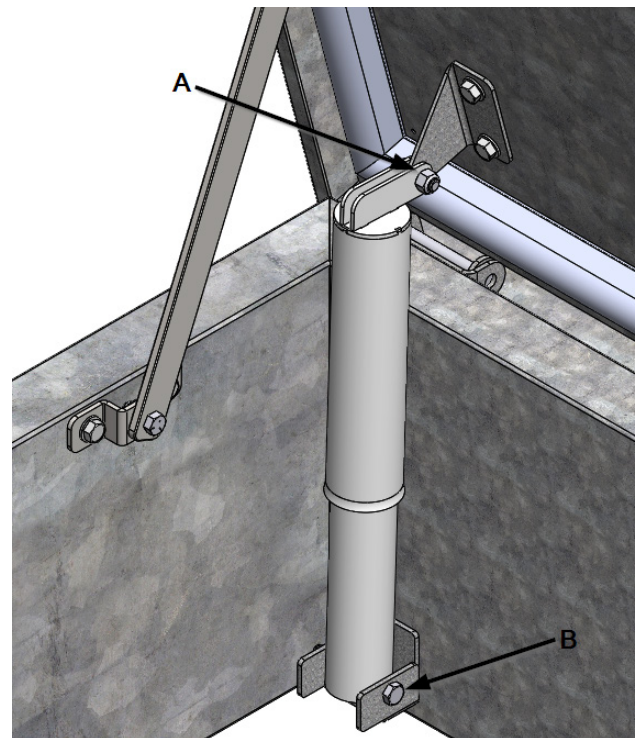

Compression Tool



9702 Newton Ave S. Bloomington, MN 55431 | 10 Locations Nationwide

800-554-6077 952-835-2218 sales@activarcpg.com www.activarcpg.com

Installation & Maintenance Guide

Installation Continued:

8. Remove steel cylinder top and spring and discard.
9. Remove bottom cylinder cover by removing bolt "B" that attaches bottom cylinder to the bracket on curb. Discard cylinder and bolts.
10. Repeat steps 2-8, on additional spring assemblies.
11. Attach drilling template as described on decal (shown below).
12. Drill holes according to location given on decal.
13. Attach new brackets for lid and curb, using drill and T30 torx head bit, with 1/4-20 x 3/4 round head torx, self-tapping screw (shown below)

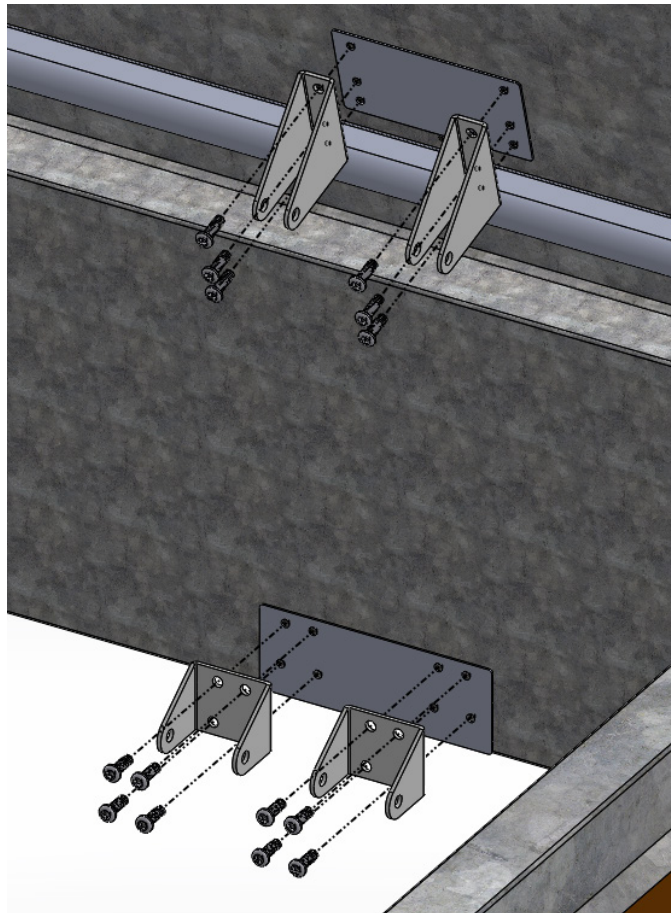

Installation Continued:

14. Using the two ½" wrenches, attach bottom spring housing cylinder to curb bracket (shown below).
15. Lubricate springs with the grease provided and nest springs within bottom spring housing cylinder.

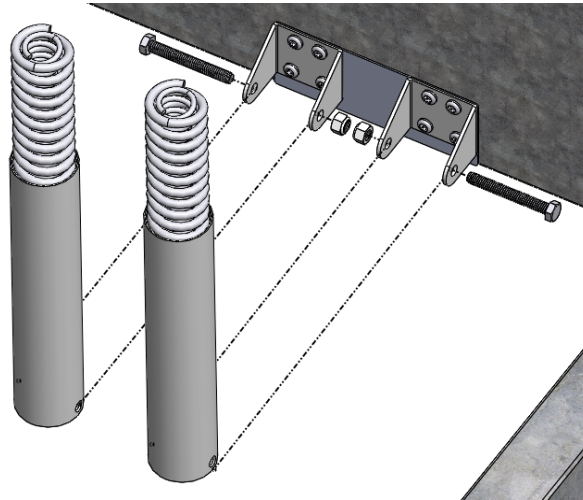

16. With springs lubricated and nested within bottom cylinder, slide the top cylinder on top of the springs
17. Use the provided spring compression clamp tool, as shown below, to allow the top cylinder to be attached to the lid



Installation Continued:

18. Secure the top cylinder to the lid bracket using two ½" wrenches (shown below)
19. Remove spring compression clamp tool.
20. Manually open and close door to check functionality of moving parts. The springs provide lift assistance while opening and closing the roof hatch door.

