

## ROOF ACCESSORIES—DURA-HATCH SERIES™ WITH SINGLE POINT LATCH & ABC OPTION- RHU

A part of Dur-Red's popular Dura-Hatch Series of roof hatch. This custom unit is called an All-But-Curb, because it comes without a curb. It is commonly used as a hatch rebuild kit. This unit is unique in that it allows you to use the existing curb and no re-roofing is needed. Models are available in aluminum or galvanized steel to meet your roof access needs.

### SPECIFICATIONS:

**Material:** Steel- 14 gauge galvanized steel curb and cover with 22 gauge galvanized steel cover liner. Aluminum—11 gauge aluminum curb and cover with 18 gauge aluminum cover liner.

**Finish:** Powder coat gray texture on steel, powder coat silver texture on aluminum

**Gasketing:** Bulb neoprene door seal

**Insulation:** 1" polyisocyanurate (R-6) on curb and in cover

**Hinges:** Heavy-duty galvanized steel or aluminum hinge with bolt pin

**Hold-Open Arm:** Clear zinc-plated steel hold-open arm with red plastic coating

**Latch:** Zinc-plated steel single point slam latch

**Springs:** Pressure intensifiers with compression spring provide lift assistance

**Sizes:** Minimum 24" x 24", Maximum: 36" x 96". (W x L where L is the hinged side)

**Order Size = Curb Opening**

### ACCESSORIES SOLD SEPARATELY:

\_\_\_ Safety Post, Safety Yellow (LP-4)

\_\_\_ Safety Railing (RSRWB)

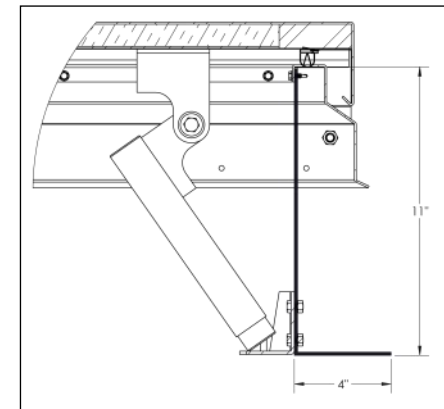
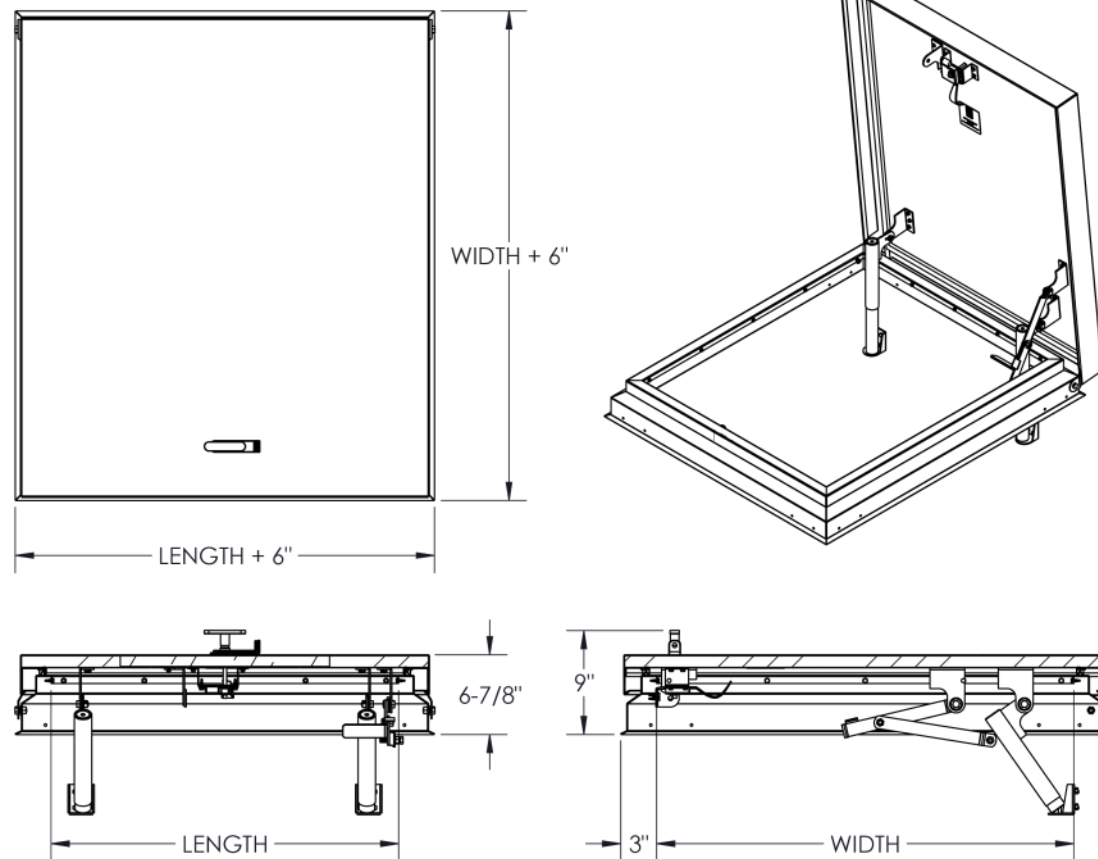

|  |  |  |   |                  |
|--|--|--|---|------------------|
|  <b>DUR-RED PRODUCTS</b><br>8702 Newton Av S, Bloomington MN 55431<br>Many Locations Nationwide | 800-554-6077<br>sales@activarcpg.com<br>www.activarcpg.com | <b>Distributor:</b><br><b>Contractor:</b><br><b>Date:</b><br>Scale: N/A  | <b>Project:</b><br><b>Approved By:</b><br><b>Architect:</b><br>Item # |                  |
|  | @2023 Activar Construction Products Group, Inc.            | THE INFORMATION CONTAINED IN THIS DRAWING IS THE SOLE PROPERTY OF ACTIVAR CONSTRUCTION PRODUCTS GROUP, INC.<br>ANY REPRODUCTION IN PART OR AS A WHOLE WITHOUT THE WRITTEN PERMISSION OF ACTIVAR CONSTRUCTION PRODUCTS GROUP, INC IS PROHIBITED | Pages: 1 of 2   | REV G 11/27/2023 |

**COMMON SIZES—RHU**

| QTY | WIDTH X LENGTH | MODEL           | PRIOR DUR-RED MODEL | MATERIAL         | TYPE   |
|-----|----------------|-----------------|---------------------|------------------|--------|
|     | 30" x 30"      | RHUA-3030ST-ABC | LHA-3030            | Aluminum         | Ladder |
|     | 36" x 30"      | RHUA-1ST-ABC    | LHA-3036            | Aluminum         | Ladder |
|     | 30" x 54"      | RHUA-2ST-ABC    | LHA-3054            | Aluminum         | Stair  |
|     | 36" x 36"      | RHUA-4ST-ABC    | LHA-3636            | Aluminum         | Ladder |
|     | 48" x 48"      | RHUA-5ST-ABC    | SSHA-4848           | Aluminum         | Ladder |
|     | 30" x 30"      | RHUG-3030GT-ABC | LHG-3030            | Galvanneal Steel | Ladder |
|     | 36" x 30"      | RHUG-1GT-ABC    | LHG-3036            | Galvanneal Steel | Ladder |
|     | 30" x 54"      | RHUG-2GT-ABC    | LHG-3054            | Galvanneal Steel | Stair  |
|     | 36" x 36"      | RHUG-4GT-ABC    | LHG-3636            | Galvanneal Steel | Ladder |
|     | 48" x 48"      | RHUG-5GT-ABC    | SSHG-4848           | Galvanneal Steel | Ladder |

**MADE-TO-ORDER RHU: EXAMPLE—RHUA-3640ST-IT**

|                          |                     |                          |                          |   |  |
|--------------------------|---------------------|--------------------------|--------------------------|---|--|
| <b>RHU</b>               | <b>MATERIAL</b>     | <b>WIDTH</b>             | <b>LENGTH</b>            | <b>FINISH</b>                                       | <b>OPTIONS</b>   |
| <input type="checkbox"/> | <b>G</b> Galvanneal | <input type="checkbox"/> | <input type="checkbox"/> | <b>GT</b> Powder Coat Gray Texture (Std for RHUG)   | <input checked="" type="checkbox"/> <b>ABC</b> All But Curb™ |
| <input type="checkbox"/> | <b>A</b> Aluminum   | <input type="checkbox"/> | <input type="checkbox"/> | <b>ST</b> Powder Coat Silver Texture (Std for RHUA) | <input type="checkbox"/> <b>RR</b> Safety Railing Ready      |
|                          |                     |                          |                          |   | <input type="checkbox"/> <b>SS</b> Stainless Hardware        |

It is the responsibility of the customer to communicate specifications and product performance requirements that are needed for their application. This document is intended to convey potential product configurations and offerings. It is not to be used to imply or represent a specification or rating, of finished products shipped. Detailed, specific submittals can be created upon request. It is the responsibility of the customer to specify product accordingly to comply with local laws, codes, and ordinances.