



MAXAM

# THERMALBLOCK™ SERIES ENERGY-EFFICIENT ROOF HATCH

*Thermally broken roof hatches provide a solution to reducing building energy costs with an R value of 20*



## **ThermalBlock Series Roof Hatch Benefits:**

- The durable construction and finish are designed to withstand heat, cold and UV exposure.
- 3" of polyisocyanurate insulation in both the curb and cover give the roof hatch a thermal resistance of R-20.
- A continuous seal around the cover maintains an air barrier between interior and exterior.
- Counterbalanced lid and easy-to-operate handle allow one-handed operation.

*See Our Website and Submittal for Product Details and Order Information*

# THERMALBLOCK™ SERIES ENERGY-EFFICIENT ROOF HATCH

## How Does the ThermalBlock System Work?

Two continuous gaskets with low thermal conductivity create a thermal block between the outside and the inside.

When the weather outside is colder, this combination of insulation and gasketing moderates the temperature on the inside of the roof hatch reducing condensation and icing. The roof hatch can also reduce the amount of heat transferred from a warmer exterior, keeping air conditioning costs lower.

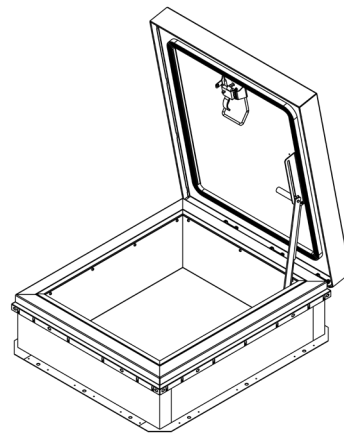
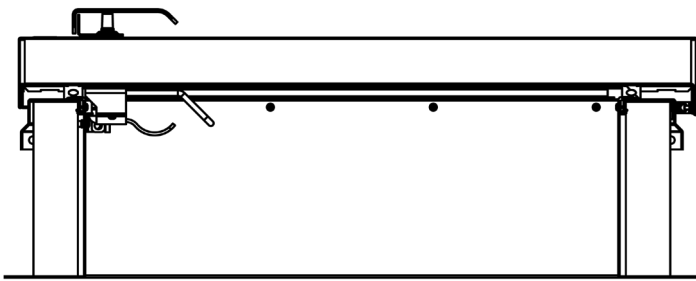

## PRODUCT SPECIFICATIONS:

- **Material:** 11 gauge aluminum.
- **Standard Finish:** Mill.
- **Curb:** Thermally broken single wall curb and counterflashing with tabs.
- **Cover:** Stiffened to support a live load of 40psf.
- **Gasket:** Extruded EPDM adhesive backed acoustic gasket seal, continuous around curb and cover to assure a continuous seal.
- **Insulation:** 3" polyisocyanurate in curb and cover with thermal resistance R-20
- **Sizes:** Minimum 26" x 24", Maximum: 48" x 120"

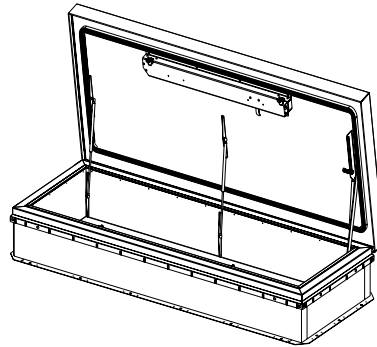

MAXAM



ACTIVAR CONSTRUCTION PRODUCTS GROUP INC.

For more info: [activarcpg.com](http://activarcpg.com) | 1-800-554-6077 | [sales@activarcpg.com](mailto:sales@activarcpg.com)  
CANADA ONLY: [maxammetal.com](http://maxammetal.com) | 604-433-4243 | [info@maxammetal.com](mailto:info@maxammetal.com)  
©2024 Activar Construction Products Group, Inc. 5/23/2024